

EV3 TECHNOLOGY

EV3 Sensors

Ultrasonic Sensor

The Ultrasonic Sensor is a digital sensor that can measure the distance to an object in front of it. It does this by sending out high-frequency sound waves and measuring how long it takes the sound to reflect back to the sensor. The sound frequency is too high for you to hear.

Distance to an object can be measured in either inches or centimeters. This allows you to program your robot to stop a certain distance from a wall.

When using centimeter units, the detectable distance is between 3 and 250 centimeters (with an accuracy of +/- 1 centimeters). When using inch units, the measurable distance is between 1 and 99 inches (with an accuracy of +/- 0.394 inches). A value of 255 centimeters or 100 inches means the sensor is not able to detect any object in front of it.

A steady light around the sensor eyes tells you that the sensor is in Measure Mode. A blinking light tells you that it is in Presence Mode.

In Presence Mode, this sensor can detect another Ultrasonic Sensor operating nearby. When listening for presence, the sensor detects sound signals but does not send them.

The Ultrasonic Sensor can help your robots avoid furniture, track a moving target, detect an intruder in your room, or “ping” with increasing volume or frequency as an object gets closer to the sensor.

For more information, see [Using the Ultrasonic Sensor](#) in the EV3 Software Help.

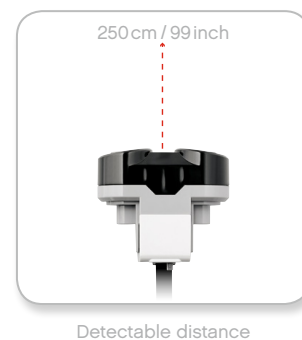

NOTE:

Since the Ultrasonic Sensor depends on reflection of the sound waves it may be ineffective at detecting surfaces that are textured or objects that are rounded. It is also possible for an object to be too small for the Ultrasonic Sensor to detect it.